

Style 230S Non-Restrained Flexible Coupling

Victaulic Bolted Split-Sleeve Products (VBSP) Style 230S stainless steel couplings (formerly Depend-O-Lok ExE) provide a non-restrained, flexible pipe joint that satisfies the requirements set forth by the AWWA C227 Standard for Bolted, Split-Sleeve Restrained and Non-Restrained Couplings for Plain-End Pipe.

This style of coupling is typically used in buried or exposed pipe applications for flexible field joint connections where either joint restraint due to thrust is not a requirement or can be accommodated using an external joint harness system such as an AWWA M11 restraint harnesses. External restraints must be installed to ensure the coupling does not exceed published values for allowable movement. Typical applications include liquid and gaseous media piping, ethanol and other chemical plant piping, pulp and paper industry piping and other piping applications that require a corrosion resistant, non-restrained flexible connections.

The dual-arched mechanical coupling body houses o-ring gaskets that provide the radial seal around the circumference of the pipe, while a sealing plate provides for the axial seal across the coupling body and pipe joint. The Style 230S coupling housing is designed to accommodate hoop stress to meet system pressure requirements while maintaining a leak-proof joint seal. The Style 230S couplings also perform at negative pipe pressures up to full vacuum. The o-ring gasket is not pressure responsive and therefore does not require internal pipe pressure to assist with the seal. The arched cross-sectional shape of the coupling provides for a high section modulus to resist forces encountered during negative pressure (submerged) or vacuum service.

Style 230S couplings are available in standard nominal sizes from 3 – 96”/80 – 2400 mm with larger sizes available based on design and application requirements. The Style 230S non-restrained coupling can accommodate operating pressures up to 300 psi/2065 kPa depending on the actual pipe diameter. For pressures and sizes not shown in the dimension and performance tables contact Victaulic for information on our engineered products.

Style 230/230S couplings provide a flexible pipe connection and are not designed or intended to transfer significant shear, bending or axial loads across the pipe joint. Therefore a single coupling will not allow for differential settlement to occur at the joint. However a minimum of two flexible couplings designed to allow dynamic (in-service) deflection and installed in combination can be used to accommodate differential settlement at a pipe joint or between a pipeline and a structure. Style 230S couplings provide 1/2”/15mm of axial movement and are not designed for use as an expansion coupling. Victaulic recommends Style 233/233S couplings for this purpose as they are specifically designed to allow for dynamic deflection and provide thrust restraint at the joint. Refer to submittal publications 60.07 and 60.08 for product details and 26.20 for guidelines regarding the use of these couplings in differential settlement application.

All flexible mechanical couplings should be properly supported to minimize or eliminate undesirable loads at the joint. Pipe support requirements are defined within Victaulic Application Guidelines. Please see submittal 26.20.

For proper closure tool selection see column marked Tool Type on pages 6-7.



3 – 96”/80 – 2400mm

JOB/OWNER

System No. _____

Location _____

CONTRACTOR

Submitted By _____

Date _____

ENGINEER

Spec Sect _____ Para _____

Approved _____

Date _____

Style 230S Non-Restrained Flexible Coupling

PRODUCT GUIDE

Product Style Guide			
Submittal Number	Style Number	Coupling/Body Material	Application
60.01	230	Carbon Steel	Non-Restrained Coupling
60.02	230S	Stainless Steel	Non-Restrained Coupling
60.03	231	Carbon Steel	Expansion Coupling
60.04	231S	Stainless Steel	Expansion Coupling
60.05	232	Carbon Steel	Restrained Coupling
60.06	232S	Stainless Steel	Restrained Coupling
60.07	233	Carbon Steel	Restrained Coupling For Dynamic Joint Deflection
60.08	233S	Stainless Steel	Restrained Coupling For Dynamic Joint Deflection
60.09	234	Carbon Steel	Restrained Single-Gasket Coupling
60.10	234S	Stainless Steel	Restrained Single-Gasket Coupling

SEGMENTED COUPLINGS

The Style 230S dimensional tables list the minimum number of coupling housing segments for a particular pipe size. For special applications, non-restrained couplings are available in two (or more) segments to allow for installation of the coupling over an existing pipe joint or to facilitate ease of handling for larger size couplings. The o-ring gaskets (except Silicone) can be furnished "split" to allow for field bonding when an existing pipe joint configuration does not allow for installation of a complete o-ring onto the pipe end.

BODY TYPE

Cross-Sections

NOTE: Body type is not optional and will be determined by system requirements.



Type 1 coupling is the basic split-sleeve coupling that provides for a flexible, non-restrained pipe joint and is generally used for smaller diameter, low pressure applications.



Type 2 coupling is a shouldered coupling. This coupling is designed to accommodate higher pressures for certain pipe diameters. The shoulders welded to the edge of the coupling body provide a vertical bearing surface and provide additional cross-sectional stiffness and typically allow for more angular deflection at the joint than a Type 1 coupling.

Style 230S Non-Restrained Flexible Coupling

COUPLING COMPONENTS

- 1. Body** – Dual arch cross-section used on Type 1 and 2.
- 2. Shoulders (Type 2 only)** – Provide additional stiffness, allow for larger o-ring to accommodate angular deflection at the pipe joint.
- 3. Closure Plates** – Low profile bolt pads for installation and tightening of coupling; gap between plates of installed coupling allows for field flexibility.
- 4. Sealing Plate** – Provides axial seal across the coupling body and pipe joint.
- 5. O-ring Gaskets** – Provide circumferential seal.
- 6. Fasteners**
 - Studs – High Strength Threaded Rod
 - Nuts – Heavy Hex Nuts
 - Washers – SAE small pattern flat washers

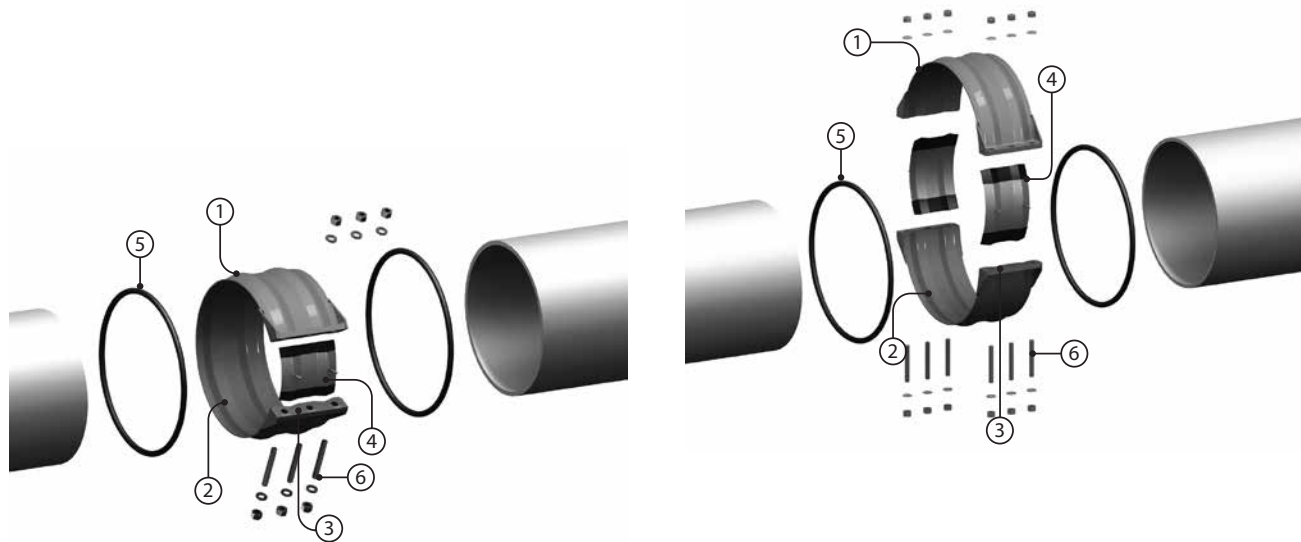

ONE SEGMENT HOUSING

TWO SEGMENT HOUSING

Style 230S Non-Restrained Flexible Coupling

MATERIAL SPECIFICATIONS

Body

Stainless Steel conforming to ASTM A240 316/316L

Shoulders (Type 2)

Stainless Steel conforming to ASTM A240 316L

Closure Plates

Stainless Steel conforming to 316L

Sealing Plate

Stainless Steel conforming to ASTM A240 316L

O-ring Gaskets

Standard (Specify choice on order):

- **EPDM** -30°F to +230°F/-34°C to +110°C
Cold and hot water within allowable temperature range; dilute acids; excellent resistance to the deteriorative effects of ozone, oxygen, heat and most chemicals not involving hydrocarbons. NOT RECOMMENDED FOR PETROLEUM SERVICES.
 - **Silicone** -30°F to +350°F/-34°C to +177°C
Dry, hot air applications; excellent resistance to many chemicals. NOT RECOMMENDED FOR HOT WATER OR STEAM APPLICATIONS.
 - **Isoprene** -40°F to +160°F/-40°C to +71°C
Water; salt water; sewage; good resistance to oxygen and dilute acids

Services listed are general service recommendations only. Refer to a chemical elastomer guide for specific applications and suitability of gasket material for services that are not listed.
- Optional gasket (specify choice on order):
- **Nitrile** -20°F to +180°F/-28°C to +82°C
Water; petroleum products, vegetable and mineral oils; air with oil vapors within allowable temperature range; good resistance to hydrocarbons; acids and bases.
 - **Fluoroelastomer** +20°F to +300°F/-7°C to +149°C
Outstanding resistance to heat and most chemicals.
 - **Neoprene** -30°F to +180°F/-34°C to +82°C
Water and wastewater; good resistance to ozone, effects of UV and some oils.

Restraint Rings

Stainless Steel conforming to ASTM A276 316L

Permanent Fasteners

Studs - Stainless Steel conforming to ASTM A193 Grade B8M 316 Class 2

Nuts - Heavy hex nuts

Stainless Steel conforming to ASTM A194 Grade 8M 316

Washers - Stainless Steel Type 316 SAE pattern

Installation Fasteners (for installation purposes only, supplied with Type 2 and Type 3 couplings)

Studs - Carbon Steel conforming to ASTM A193 Grade B7 zinc plated

Nuts - Heavy hex nuts

Carbon Steel conforming to ASTM A194 Grade 2H zinc plated

Washers - Carbon Steel SAE small pattern flat washers conforming to ASTM F436 SAE pattern zinc plated

Style 230S Non-Restrained Flexible Coupling

PIPE END DIMENSIONAL TOLERANCE AND OVALITY

For specific pipe diameter tolerances, pipe ovality (roundness) requirements and minimum/maximum pipe diameter allowance, refer to the tables included in the Installation Manuals (below) and 26.20 Application Guidelines.

I-230.S1 - Styles 230/230S Non-Restrained Coupling (Types 1 & 2, One Segment)

I-230.S2 - Styles 230/230S Non-Restrained Coupling (Types 1 & 2, Two Segments)

Style 230S Non-Restrained Flexible Coupling

DIMENSIONS

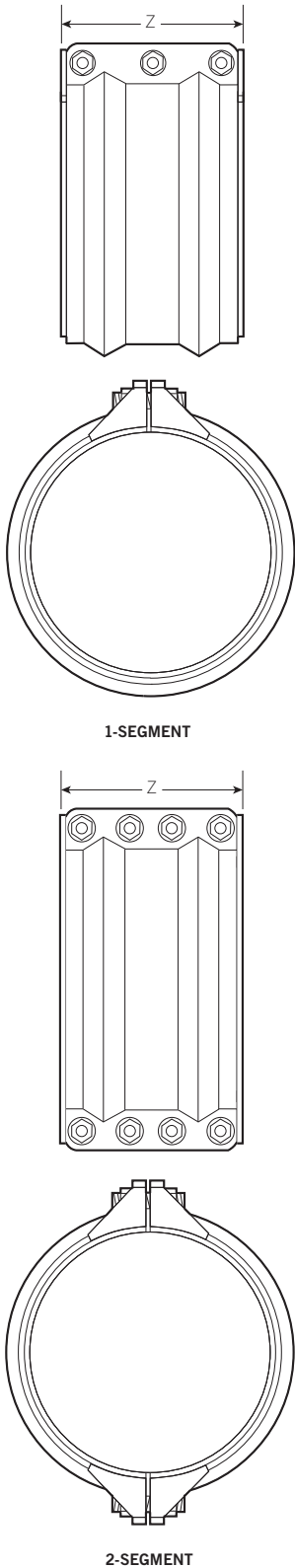

(1) Nominal Pipe Size In./mm	(2) Actual Pipe O.D. Range In./mm	(3) Maximum Working Pressure psi/kPa	Coupling Dimensions		(4) Min. No. of Coupling Segments	No. of Fasteners - Fastener Dimensions Dia. x Length In. x In.	(5) Approximate Weight Each Lbs./Kg.	Body Type	(6) Tool Type
			Body Thickness In.	Width (Z) In./mm					
3 80	2.88 - 3.50 73.2 - 88.9	300 2065	14 ga.	5.25 133.4	1	3 - 1/2 x 3 1/4	5.0 2.3	1	A
4 100	3.63 - 4.88 92.2 - 124.0	300 2065	14 ga.	5.25 133.4	1	3 - 1/2 x 3 1/4	5.0 2.3	1	A
6 150	5.00 - 6.88 127.0 - 174.8	300 2065	12 ga.	8.00 203.2	1	3 - 1/2 x 3 1/4	12.0 5.4	1	A
8 200	7.00 - 8.88 177.8 - 225.6	200 2065	11 ga.	10.00 254.0	1	3 - 5/8 x 5	20.0 9.1	1	B,C
10 250	9.00 - 10.88 228.6 - 276.4	200 1380	10 ga.	10.00 254.0	1	3 - 5/8 x 5	23.0 10.4	1	B,C
12 300	11.00 - 12.88 279.4 - 327.2	200 1380	10 ga.	10.00 254.0	1	3 - 5/8 x 5	27.0 12.2	1	B,C
14 350	13.00 - 14.88 330.2 - 378.0	200 1380	10 ga.	10.00 254.0	1	3 - 5/8 x 5	30.0 13.6	1	B,C
16 400	15.00 - 16.88 381.0 - 428.8	200 1380	3/16	10.00 254.0	1	3 - 3/4 x 6	46.0 20.9	1	B,C
		300 2065	3/16	10.50 266.70	1	3 - 3/4 x 6	67.0 30.4	2	B,C
18 450	17.00 - 18.88 431.8 - 479.6	150 1035	3/16	10.00 254.0	1	3 - 3/4 x 6	50.0 22.7	1	B,C
		250 1725	3/16	10.50 266.7	1	3 - 3/4 x 6	72.0 32.7	2	B,C
20 500	19.00 - 21.88 482.6 - 555.8	150 1035	3/16	10.00 254.0	1	3 - 3/4 x 6	54.0 24.5	1	B,C
		250 1725	3/16	10.50 266.7	1	3 - 3/4 x 6	78.0 35.4	2	B,C
24 600	22.00 - 26.88 558.8 - 682.8	100 690	3/16	10.00 254.0	1	3 - 3/4 x 6	64.0 29.0	1	B,C
		200 1380	3/16	10.50 266.7	1	3 - 3/4 x 6	92.0 41.7	2	B,C
		250 1725	1/4	12.50 317.5	1	4 - 3/4 x 6	123.0 55.8	2	C
30 750	27.00 - 32.88 685.8 - 835.2	100 690	3/16	10.00 254.0	1	3 - 3/4 x 6	76.0 34.5	1	B,C
		200 1380	1/4	12.50 317.5	1	3 - 3/4 x 6	149.0 67.6	2	C
		300 2065	3/8	12.50 317.5	2	8 - 7/8 x 8	329.0 149.2	2	C
36 900	33.00 - 38.88 838.2 - 987.6	75 500	3/16	10.00 254.0	1	3 - 3/4 x 6	89.0 40.4	1	B,C
		175 1200	1/4	12.50 317.5	1	3 - 3/4 x 6	173.0 78.5	2	C
		250 1725	3/8	12.50 317.5	2	8 - 7/8 x 8	377.0 171.0	2	C
42 1050	39.00 - 44.88 990.6 - 1140.0	50 350	3/16	10.00 254.0	1	3 - 3/4 x 6	101.0 45.8	1	B,C
		150 1035	1/4	12.50 317.5	1	4 - 3/4 x 6	197.0 89.4	2	C
		200 1380	3/8	12.50 317.5	2	8 - 7/8 x 8	422.0 191.4	2	C
		250 1725	1/2	14.50 368.3	2	8 - 1 x 8	638.0 289.4	2	C

(1) Couplings must be used on pipe with a minimum wall thickness that meets the requirements of AWWA C220 for stainless steel pipe.
 (2) For actual Pipe O.D. round down to the nearest 1/8" to determine proper coupling size required.
 (3) For allowable test or transient pressure, the maximum working pressure may be increased to 1 1/2 times the values shown.
 (4) 1-segment couplings may be available as 2-segment couplings to allow for in-place pipe installations. Contact Victaulic for details.
 (5) Coupling weights are based on nominal pipe diameter and include all accessories. Weight may vary based on actual size of pipe.
 (6) Closure Tool Recommendations:
 A= CTM-01 Small Manual Closure Tool
 B= CTM-02 Large Manual Closure Tool
 C= CTH-01 10-Ton Hydraulic Closure Tool
 *For more details on closure tools refer to page 10.
 Note: The data in this table only applies when stainless steel couplings are being used on stainless steel pipe.

Style 230S Non-Restrained Flexible Coupling

DIMENSIONS

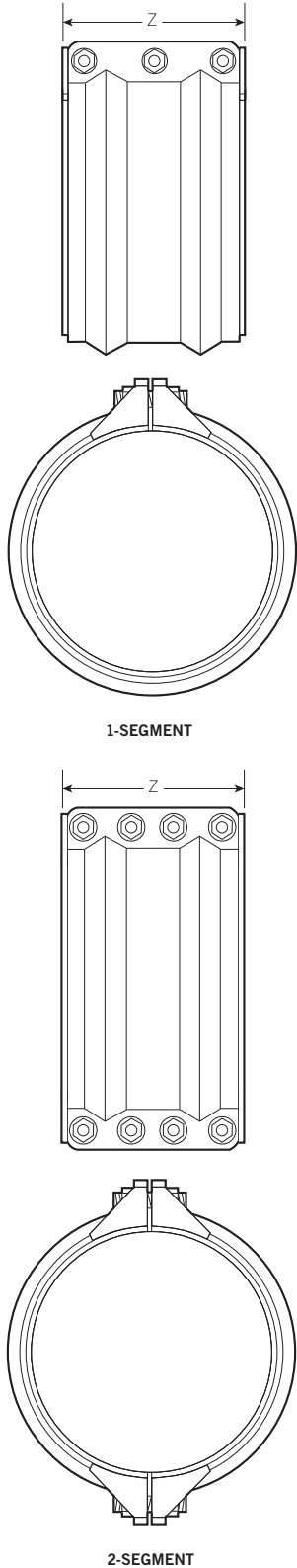

(1) Nominal Pipe Size In./mm	(2) Actual Pipe O.D. Range In./mm	(3) Maximum Working Pressure psi/kPa	(4) Coupling Dimensions		(4) Min. No. of Coupling Segments	(5) No. of Fasteners - Fastener Dimensions Dia. x Length In. x In.	(5) Approximate Weight Each Lbs./Kg.	(6) Body Type	(6) Tool Type
			Body Thickness In.	Width (Z) In./mm					
48 1200	45.00 - 50.88 1143.0 - 1292.4	50 350	3/16	10.00 254.0	1	3 - 3/4 x 6	112.0 50.8	1	B,C
		150 1035	1/4	12.50 317.5	1	4 - 3/4 x 6	221.0 100.2	2	C
		200 1380	3/8	12.50 317.5	2	8 - 7/8 x 8	467.0 211.8	2	C
		250 1725	1/2	14.50 368.3	2	8 - 1 x 8	709.0 321.6	2	C
54 1350	51.00 - 56.88 1295.4 - 1444.8	100 690	1/4	12.50 317.5	1	4 - 7/8 x 8	297.0 134.7	2	C
		175 1200	3/8	12.50 317.5	2	8 - 7/8 x 8	522.0 236.8	2	C
		250 1725	1/2	14.50 368.3	2	8 - 1 x 8	780.0 353.8	2	C
60 1500	57.00 - 62.88 1447.8 - 1597.2	100 690	1/4	12.50 317.5	2	8 - 7/8 x 8	375.0 170.1	2	C
		150 1035	3/8	12.50 317.5	2	8 - 7/8 x 8	570.0 258.5	2	C
		200 1380	1/2	14.50 368.3	2	8 - 1 x 8	851.0 386.0	2	C
66 1650	63.00 - 68.88 1600.2 - 1749.6	150 1035	3/8	12.50 317.5	2	8 - 7/8 x 8	605.0 274.4	2	C
		200 1380	1/2	14.50 368.3	2	8 - 1 x 8	904.0 410.0	2	C
72 1800	69.00 - 74.88 1752.6 - 1902.0	125 875	3/8	12.50 317.5	2	8 - 7/8 x 8	654.0 296.6	2	C
		175 1200	1/2	14.50 368.3	2	8 - 1 x 8	975.0 442.3	2	C
78 1950	75.00 - 80.88 1905.0 - 2054.4	125 875	3/8	12.50 317.5	2	8 - 7/8 x 8	689.0 312.5	2	C
		175 1200	1/2	14.50 368.3	2	8 - 1 x 8	1045.0 474.0	2	C
84 2100	81.00 - 86.88 2057.4 - 2206.8	100 690	3/8	12.50 317.5	2	8 - 7/8 x 8	737.0 334.3	2	C
		150 1035	1/2	14.50 368.3	2	8 - 1 x 8	1098.0 498.0	2	C
90 2250	87.00 - 92.88 2209.8 - 2359.2	100 690	3/8	12.50 317.5	2	8 - 7/8 x 8	773.0 350.6	2	C
		150 1035	1/2	14.50 368.3	2	8 - 1 x 8	1152.0 522.5	2	C
96 2400	93.00 - 102.00 2362.2 - 2590.8	100 690	3/8	12.50 317.5	2	8 - 7/8 x 8	831.0 376.9	2	C
		150 1035	1/2	14.50 368.3	2	8 - 1 x 8	1238.0 561.5	2	C

- (1) Couplings must be used on pipe with a minimum wall thickness that meets the requirements of AWWA C220 for stainless steel pipe.
 - (2) For actual Pipe O.D. round down to the nearest 1/8" to determine proper coupling size required.
 - (3) For allowable test or transient pressure, the maximum working pressure may be increased to 1 1/2 times the values shown.
 - (4) 1-segment couplings may be available as 2-segment couplings to allow for in-place pipe installations. Contact Victaulic for details.
 - (5) Coupling weights are based on nominal pipe diameter and include all accessories. Weight may vary based on actual size of pipe.
 - (6) Closure Tool Recommendations: *
 A= CTM-01 Small Manual Closure Tool
 B= CTM-02 Large Manual Closure Tool
 C= CTH-01 10-Ton Hydraulic Closure Tool
- *For more details on closure tools refer to page 10.
 Note: The data in this table only applies when stainless steel couplings are being used on stainless steel pipe.

Style 230S Non-Restrained Flexible Coupling

PERFORMANCE

Nominal Pipe Size In./mm	(1)			Body Type	(2) Pipe End Separation Min - Max In./mm	(3) Max. Allow. Static Deflection Degrees
	Maximum Working Pressure psi/kPa Carbon Steel	Maximum Working Pressure psi/kPa Stainless Steel	Maximum Working Pressure psi/kPa Ductile Iron			
3 80	300 2065	300 2065	300 2065	1	0 - 0.75 0 - 19.1	5° 0'
4 100	300 2065	300 2065	300 2065	1	0 - 0.75 0 - 19.1	5° 0'
6 150	300 2065	300 2065	300 2065	1	0 - 1.25 0 - 31.8	4° 30'
8 200	200 1375	200 1375	200 1375	1	0 - 1.50 0 - 38.1	4° 0'
10 250	200 1375	200 1375	200 1375	1	0 - 1.50 0 - 38.1	4° 0'
12 300	200 1375	200 1375	200 1375	1	0 - 1.50 0 - 38.1	4° 0'
14 350	200 1375	200 1375	200 1375	1	0 - 1.50 0 - 38.1	4° 0'
16 400	200 1375	200 1375	200 1375	1	0 - 1.50 0 - 38.1	3° 30'
	300 2065	300 2065	300 2065	2	0 - 1.50 0 - 38.1	3° 30'
18 450	150 1035	150 1035	150 1035	1	0 - 1.50 0 - 38.1	3° 30'
	250 1725	250 1725	250 1725	2	0 - 1.50 0 - 38.1	3° 30'
20 500	150 1035	150 1035	150 1035	1	0 - 1.50 0 - 38.1	3° 30'
	250 1725	250 1725	250 1725	2	0 - 1.50 0 - 38.1	3° 30'
24 600	100 690	100 690	100 690	1	0 - 1.50 0 - 38.1	3° 0'
	200 1375	200 1375	200 1375	2	0 - 1.50 0 - 38.1	3° 0'
	250 1725	250 1725	250 1725	2	0 - 3.00 0 - 76.2	3° 0'
30 750	100 690	100 690	100 690	1	0 - 1.50 0 - 38.1	2° 30'
	200 1375	200 1375	200 1375	2	0 - 3.00 0 - 76.2	3° 0'
	300 2065	300 2065	300 2065	2	0 - 3.00 0 - 76.2	3° 0'
36 900	75 515	75 515	75 515	1	0 - 1.50 0 - 38.1	2° 15'
	175 1200	175 1200	175 1200	2	0 - 3.00 0 - 76.2	3° 0'
	250 1725	250 1725	250 1725	2	0 - 3.00 0 - 76.2	3° 30'
42 1050	50 345	50 345	50 345	1	0 - 1.50 0 - 38.1	2° 0'
	150 1035	150 1035	150 1035	2	0 - 3.00 0 - 76.2	2° 30'
	200 1375	200 1375	200 1375	2	0 - 3.00 0 - 76.2	2° 30'
	250 1725	250 1725	250 1725	2	0 - 3.00 0 - 76.2	2° 30'

(1) For allowable test or transient pressure, the maximum working pressure may be increased to 1½ times the values shown.

(2) Style 230 couplings provide ½"/15 mm of axial movement within the published pipe end separation range and are not designed for use as an expansion coupling.

(3) Published deflection values are intended for installation only. Allowable in-service or dynamic deflection is limited by the maximum allowable axial movement at the joint. Contact Victaulic for details.

Style 230S Non-Restrained Flexible Coupling

PERFORMANCE

Nominal Pipe Size In./mm	(1)			Body Type	(2) Pipe End Separation Min - Max In./mm	(3) Max. Allow. Static Deflection Degrees
	Maximum Working Pressure psi/kPa Carbon Steel	Maximum Working Pressure psi/kPa Stainless Steel	Maximum Working Pressure psi/kPa Ductile Iron			
48 1200	50 345	50 345	50 345	1	0 - 1.50 0 - 38.1	1° 45'
	150 1035	150 1035	150 1035	2	0 - 3.00 0 - 76.2	2° 30'
	200 1375	200 1375	200 1375	2	0 - 3.00 0 - 76.2	2° 30'
	250 1725	250 1725	250 1725	2	0 - 3.00 0 - 76.2	2° 30'
54 1350	100 690	100 690	100 690	2	0 - 3.00 0 - 76.2	2° 0'
	175 1200	175 1200	175 1200	2	0 - 3.00 0 - 76.2	2° 0'
	250 1725	250 1725	250 1725	2	0 - 3.00 0 - 76.2	2° 0'
60 1500	100 690	100 690	100 690	2	0 - 3.00 0 - 76.2	1° 45'
	150 1035	150 1035	150 1035	2	0 - 3.00 0 - 76.2	1° 45'
	200 1375	200 1375	200 1375	2	0 - 3.00 0 - 76.2	1° 45'
66 1650	150 1035	150 1035	150 1035	2	0 - 3.00 0 - 76.2	1° 30'
	200 1375	200 1375	200 1375	2	0 - 3.00 0 - 76.2	1° 30'
72 1800	125 860	125 860	125 860	2	0 - 3.00 0 - 76.2	1° 30'
	175 1200	175 1200	175 1200	2	0 - 3.00 0 - 76.2	1° 30'
78 1950	125 860	125 860	125 860	2	0 - 3.00 0 - 76.2	1° 0'
	175 1200	175 1200	175 1200	2	0 - 3.00 0 - 76.2	1° 0'
84 2100	100 690	100 690	100 690	2	0 - 3.00 0 - 76.2	1° 0'
	150 1035	150 1035	150 1035	2	0 - 3.00 0 - 76.2	1° 0'
90 2250	100 690	100 690	100 690	2	0 - 3.00 0 - 76.2	1° 0'
	150 1035	150 1035	150 1035	2	0 - 3.00 0 - 76.2	1° 0'
96 2400	100 690	100 690	100 690	2	0 - 3.00 0 - 76.2	1° 0'
	150 1035	150 1035	150 1035	2	0 - 3.00 0 - 76.2	1° 0'

(1) For allowable test or transient pressure, the maximum working pressure may be increased to 1½ times the values shown.

(2) Style 230 couplings provide ½"/15 mm of axial movement within the published pipe end separation range and are not designed for use as an expansion coupling.

(3) Published deflection values are intended for installation only. Allowable in-service or dynamic deflection is limited by the maximum allowable axial movement at the joint. Contact Victaulic for details.

Style 230S Non-Restrained Flexible Coupling

CLOSURE TOOLS



MANUAL TOOL



HYDRAULIC TOOL

Manual Tools

- CTM-01: for use on 5" and 8" body widths
- CTM-02: for use on 10" body widths
for use on 12" body widths with thickness of $\frac{3}{16}$ " or less

Hydraulic Tools

- CTH-01*: for use on 12" body widths with thickness of $\frac{1}{4}$ " or greater
for use on 14", 16" and 18" body widths
- CTH-02: for use on all type 3 couplings

- Hydraulic tool package comes standard with:

- one (1) tool head
- one (1) hydraulic cylinder
- one (1) hydraulic hose
- one (1) hand pump

* A CTH-01 hydraulic closure tool can be used in applications where the CTM-02 manual closure tool is recommended.

Note: The closure tools listed above are designed specifically for Victaulic Style 230, 231, 232 and 233 couplings. If ordering custom product, contact Victaulic for appropriate tool selection.

Style 230S Non-Restrained Flexible Coupling

PRODUCT CONFIGURATOR

C 0230 0096 50 X 2 D E 0 X 00

Class	Style	Actual Pipe O.D.*		Body Type	Segments	PSI/kPa Rating	Rubber Compound	Paint	Hardware	Options
		Inches [^]	Fraction							
C	0230	0002 through 0102	00 - 0 13 - 1/8 25 - 1/4 38 - 3/8 50 - 1/2 63 - 5/8 75 - 3/4 88 - 7/8	X - Stainless	1 - One 2 - Two	B - 50/345 C - 75/515 D - 100/690 E - 125/860 F - 150/1035 G - 175/1200 H - 200/1375 J - 250/1725 K - 300/2065	E - EPDM I - Isoprene L - Silicone T - Nitrile V - Neoprene O - Fluoro-elastomer	0 - None	X - Stainless	00 - None 01 - Pipe Stops

[^] Couplings are available in a range of nominal sizes from 3 - 96".
 * For actual pipe O.D. round down to the nearest 1/8" to determine proper coupling size required.

ENGINEERED PRODUCTS OPTIONS

For non-standard products the Victaulic Engineered Products group can assist with specialty joints designed to meet the specific size, pressure and temperature requirements of your system. The Engineered Products group will also provide pricing and availability for options such as pipe stops and insulating sleeves.

WARRANTY

Refer to the Warranty section of the current Price List or contact Victaulic for details.

NOTE

This product shall be manufactured by Victaulic or to Victaulic specifications. All products to be installed in accordance with current Victaulic installation/assembly instructions. Victaulic reserves the right to change product specifications, designs and standard equipment without notice and without incurring obligations.

TESTING

Victaulic Style 230S couplings are designed to allow for a 50 percent increase over the published maximum working pressure for test and/or transient pressures. Due to the huge volume of air that can be involved in jobsite air testing and the nature of air or gas that is pressurized, jobsite air testing should be limited to 25 psi/175 kPa or less.

For complete contact information, visit www.victaulic.com

60.02 3363 REV J UPDATED 08/2013

VICTAULIC IS A REGISTERED TRADEMARK OF VICTAULIC COMPANY. © 2013 VICTAULIC COMPANY. ALL RIGHTS RESERVED.

