

Accessories

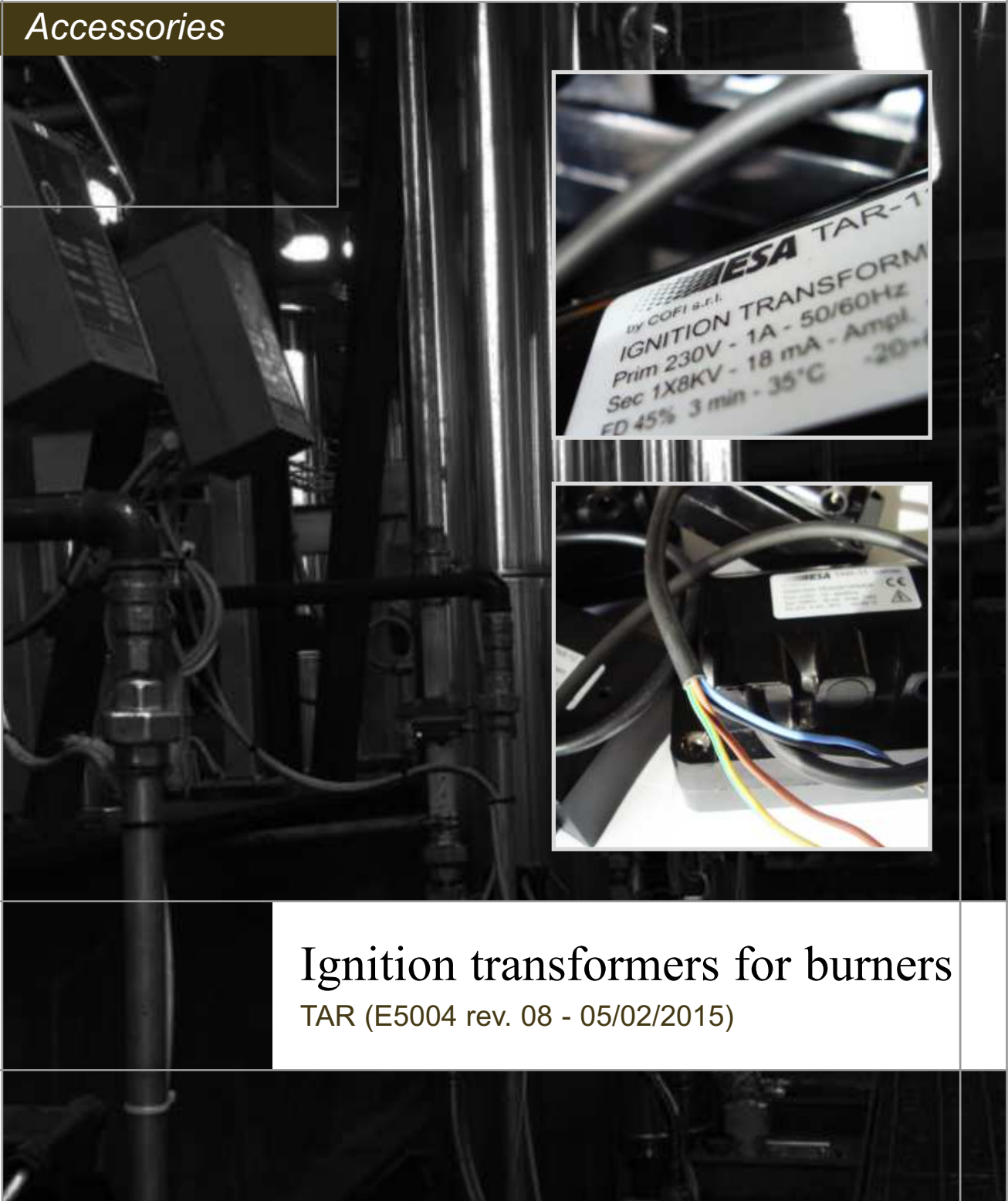

Ignition transformers for burners

TAR (E5004 rev. 08 - 05/02/2015)

GENERAL WARNINGS:



■ All installation, maintenance, ignition and setting must be performed by qualified staff, respecting the norms present at the time and place of the installation.

■ To avoid damage to people and things, it is essential to observe all the points indicated in this handbook. The reported indications do not exonerate the Client/User from observing general or specific laws concerning accidents and environmental safeguarding.

■ The operator must wear proper DPI clothing (shoes, helmets...) and respect the general safety, prevention and precaution norms.

■ To avoid the risks of burns or high voltage electrocution, the operator must avoid all contact with the burner and its control devices during the ignition phase and while it is running at high temperatures.

■ All ordinary and extraordinary maintenance must be performed when the system is stopped.

■ To assure correct and safe use of the combustion plant, it is of extreme importance that the contents of this document be brought to the attention of and be meticulously observed by all personnel in charge of controlling and working the devices.

■ The functioning of a combustion plant can be dangerous and cause injuries to persons or damage to equipment. Every burner must be provided with certified combustion safety and supervision devices.

■ The burner must be installed correctly to prevent any type of accidental/undesired heat transmission from the flame to the operator or the equipment.

■ The performances indicated in this technical document regarding the range of products are a result of experimental tests carried out at ESA-PYRONICS. The tests have been performed using ignition systems, flame detectors and supervisors developed by ESA-PYRONICS. The respect of the above mentioned functioning conditions cannot be guaranteed if equipment, which is not present in the ESA-PYRONICS catalogue, is used.

DISPOSAL:



To dispose of the product, abide by the local legislations regarding it.

GENERAL NOTES:



■ In accordance to the internal policy of constant quality improvement, ESA-PYRONICS reserves the right to modify the technical characteristics of the present document at any time and without warning.

■ It is possible to download technical sheets which have been updated to the latest revision from the **www.esa-pyronics.com** website.

■ The products manufactured by ESA-PYRONICS have been created in conformity to the **UNI EN 746-2:2010** Norms: Equipment for industrial thermal process - Part 2: Safety requirements for combustion and the movement and treatment of combustible elements. This norm is in harmony with the Machine Directive **2006/42/CE**. It is certified that the products in question respect all the requirements prescribed by the above mentioned Norms and Directives.

■ Certified in conformity with the **UNI EN ISO 9001** Norm by DNV GL.

CERTIFICATIONS:



EN61558-2-3: Safety of transformers, power supply units and similar devices. Particular requirements for ignition transformers for gas and diesel fuel burners, in accordance with Directive **2014/35/UE**.

CONTACTS / SERVICE:



Headquarters:

Esa S.p.A.
Via Enrico Fermi 40
24035 Curno (BG) - Italy
Tel +39.035.6227411
Fax +39.035.6227499
esa@esacombustion.it

International Sales:

Pyronics International s.a.
Zoning Industriel, 4ème rue
B-6040 Jumet - Belgium
Tel +32.71.256970
Fax +32.71.256979
marketing@pyronics.be

www.esapyronics.com

The abbreviation TAR identifies a series of specific transformers for the ignition of gas and fuel oil burners. They will in this case generate a spark which triggers off the the ignition of the industrial burners.

APPLICATIONS

- Electric ignition for gas burners
- Electric ignition for diesel burners
- Electric ignition for oil burners
- Ignition and flame detection with unirod electrode

CHARACTERISTICS

TAR-10 TRANSFORMER:

- Primary voltage: 115 / 230V
- Primary frequency: 50 / 60Hz
- Primary current: 2/1A
- Secondary voltage: 1 x 8KV
- Secondary frequency: 50 / 60Hz
- Secondary current: 20mA
- Power consumption: 220VA
- Duty cycle over 3 min. ED: 19% Ta ≤ 35°C
- Mass: 1.3 kg
- Protection degree: IP20
- Power cable length: 18 cm
- HV cable connection: self threading
- HV cable type: silicon (external diameter 7 mm)
- Maximum HV cable length 1 m (max 5 m)
- Working temperature -20÷60 °C
- Transformer use: ignition and detection
- Mounting position: any
- Transformer type: winding
- Distance between ignition electrode terminal and burner mass: 3 mm ± 0,5

NB:The TAR-10 transformer replaces the discontinued models series TAR-2/4/6/7/8.

TRANSFORMER TAR-11:

- Primary voltage: 115 / 230V
- Primary frequency: 50 / 60Hz
- Primary current: 2/1A
- Secondary voltage: 1 x 8KV
- Secondary frequency: 50 / 60Hz
- Secondary current: 18mA
- Power consumption: 220VA
- Duty cycle over 3 min. ED: 45% Ta ≤ 35°C
- Mass: 2 kg
- Protection degree: IP20
- Power cable length: 38 cm
- HV cable connection: self threading
- Hv cable type: silicon (external diameter 7 mm)
- HV cable length: 1 m (max 5 m)
- Working temperature -20÷60 °C
- Transformer use: only ignition
- Mounting position: any
- Transformer type: winding

TAR-10



F5004103

TAR-11



F5004104

- Distance between ignition electrode terminal and burner mass: 3 mm ± 0,5

NB:The TAR-11 transformer replaces the discontinued models series TAR-2/4/6/7/8.

CHARACTERISTICS

TRANSFORMER TAR-12:

■ Primary voltage:	230V
■ Primary frequency:	50 / 60Hz
■ Primary current:	0.3A
■ Secondary voltage:	1 x 10KV
■ Secondary frequency:	10KHz
■ Secondary current:	20mA
■ Power consumption:	70VA
■ Duty cycle over 3 min. ED:	20% Ta ≤ 35°C
■ Mass:	0.4 kg
■ Protection degree:	IP20
■ Power cable length:	18 cm
■ HV cable connection:	self threading
■ Hv cable type:	silicon (external diameter 7 mm)
■ HV cable length:	max 1m
■ Working temperature	0÷60 °C
■ Transformer use:	ignition and detection
■ Mounting position:	any
■ Transformer type:	electronic
■ Length of electrode attached	max 250mm
■ Length of electrode metal shield:	max 100mm
■ Distance between ignition electrode terminal and burner mass:	3 mm ± 0,5

NB: The transformer TAR-12 replaces the discontinued model series TAR-6.

TRANSFORMER TAR-13:

■ Primary voltage:	115 / 230V
■ Primary frequency:	50 / 60Hz
■ Primary current:	0.8 / 0.4A
■ Secondary voltage:	1x6KV
■ Secondary frequency:	50 / 60Hz
■ Secondary current:	10mA
■ Power consumption:	100VA
■ Duty cycle over 3 min. ED:	100% Ta ≤ 35°C (permanent service)
■ Mass:	2 kg
■ Protection degree:	IP20
■ Power cable length:	38 cm
■ HV connection:	self threading
■ HV cable type:	silicon (external diameter 7 mm)
■ HV cable length:	1 m (max 5 m)
■ Working temperature	-20÷60 °C
■ Transformer use:	only ignition
■ Mounting position:	any
■ Transformer type:	winding
■ Distance between ignition electrode terminal and burner mass:	3 mm ± 0,5

NB: The transformer TAR-13 replaces the discontinued model series TAR-5.

TAR-12



F5004105

TAR-13



F5004105

DESCRIPTION

The TAR ignition transformers can be used with all types of flame control devices and on all types and shapes of electrodes. According to the model chosen, you can also use only one electrode for burner ignition and the subsequent flame signal detection.

The permanent operation version (100% duty cycle) can be managed by other control devices that are not flame control devices considering that they can work for long periods of time.

The connection between the ignition transformer and the burner electrode must be carried out with specific HV cables and connectors (see data sheet E5001).

To increase the IP protection degree or for simplified on-field fixing, we suggest you mount the ignition transformer inside the optional ESA-TRAFO box (see data sheet E5005).

FUNCTIONING

The TAR ignition transformers generate the ignition spark of industrial burners. In particular when energized by power voltage, they generate a high voltage on the output.

The transformer output, also defined as high voltage output HV is directly connected to the burner ignition electro-

de, which has its terminal point near the metallic mass and at the triggering point of the flame. At the moment in which the electrode is energized by high voltage, it discharges towards the metallic mass generating an electronic arch that raises the air temperature enough to trigger off the fuel.

FUNCTIONING

DUTY CYCLE

The ignition transformer has a functioning limit within the duty cycle time which is expressed as a percentage with respect to a period of 3 minutes.

The duty cycle value is fundamental in the choice of model to be installed according to the application.

This parameter indicates the maximum time of operation in the 3-minute period that does not cause overheating in the transformer, rated at an ambient temperature of 35°C. The value of the duty cycle decreases proportionally becoming about 60% at 60°C.

The evaluation of the maximum operating time of the transformer in the 3 minute period is obtained with:

$$\text{Transformer working time (sec)} = \frac{[\text{Duty cycle (\%)} / 100\%]}{100} \times 180 \text{ sec}$$

Taking into consideration the transformer TAR-10 (19% duty cycle at 35 °C), when installed in an environment with a temperature lower than 35 °C, it can operate for 34 seconds, and should be turned off for the remaining 146 seconds. Considering that the transformer is only active during burner ignition, assuming a turn-on time of 5 seconds, it appears that in 180 seconds up to six burner starts (ignitions) can be carried out, equal to two per minute.

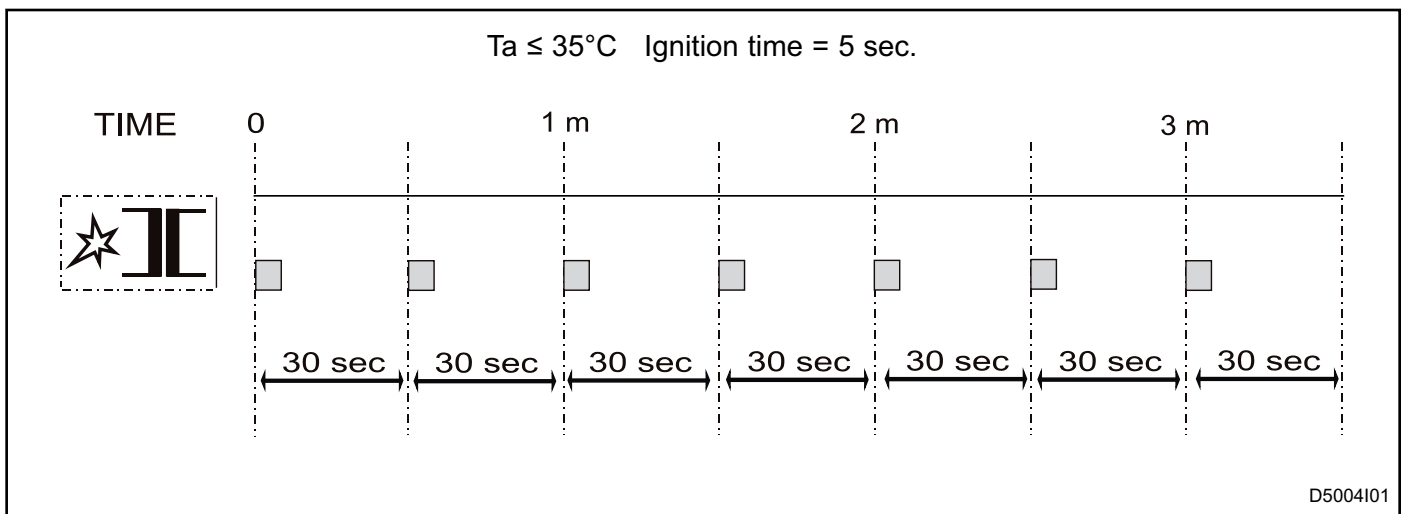

When the ambient temperature is 60 °C, the value of the TAR-10 duty cycle pattern decreases from 19% to 11.4% in 3 minutes. Consequently, the working time of the trans-

former drops to 20.5 seconds of 180 seconds limiting the number of ignitions of the burner in a period of three minutes to four.

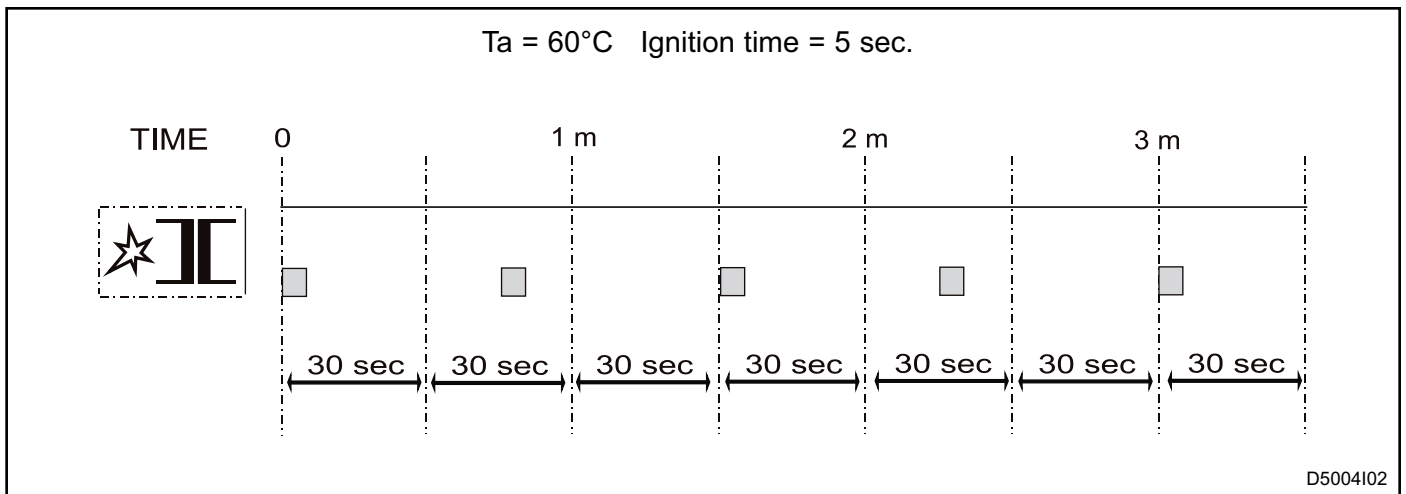

EXAMPLES OF APPLICATION 1 - TAR

The TAR ignition transformer is used to trigger off burners that have a specific electrode for ignition and another electrode or UV probe for the detection of flame presence. With the use of the transformer only for ignition, the electric connection has the HV output connected to the

relative burner ignition electrode (BI), while the other transformer secondary head must be connected to earth (see paragraph "Electric wiring"). In this application you can use TAR-10, TAR-11, TAR-12 and TAR-13 models taking account of intermittent operation of the transformer.

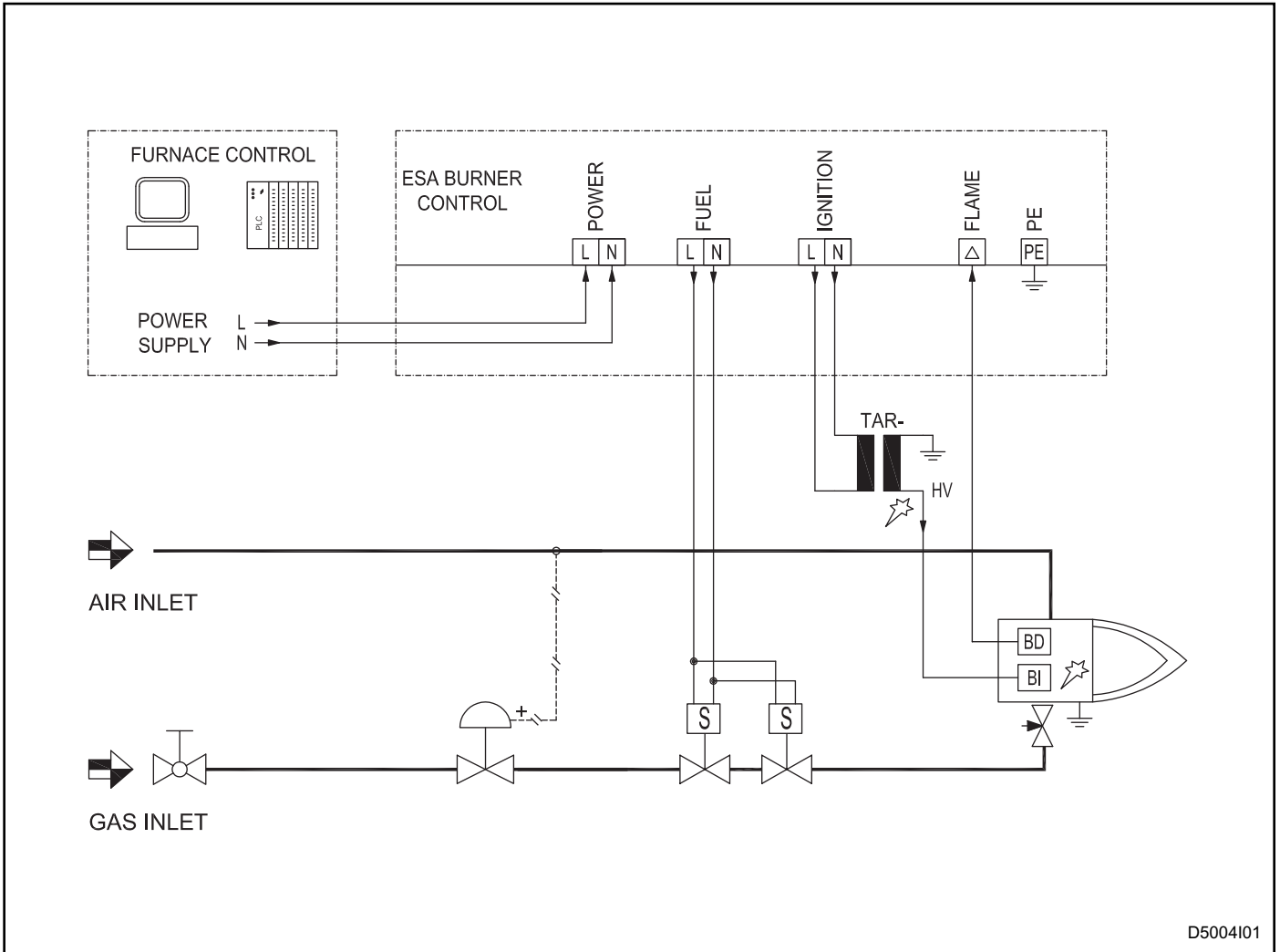

EXAMPLES OF APPLICATION 2 - TAR

The TAR ignition transformer is used to trigger off a burner that has only one electrode for ignition and flame presence signal detection.

With the use of the transformer for ignition and detection, the electric wiring has the HV output connected to the only burner electrode (BID), while the other transformer

secondary head must be connected to the flame input of the control instrument (see paragraph "Electric wiring"). In this application you can use TAR-10 and TAR-12 models taking account of intermittent operation of the transformer.

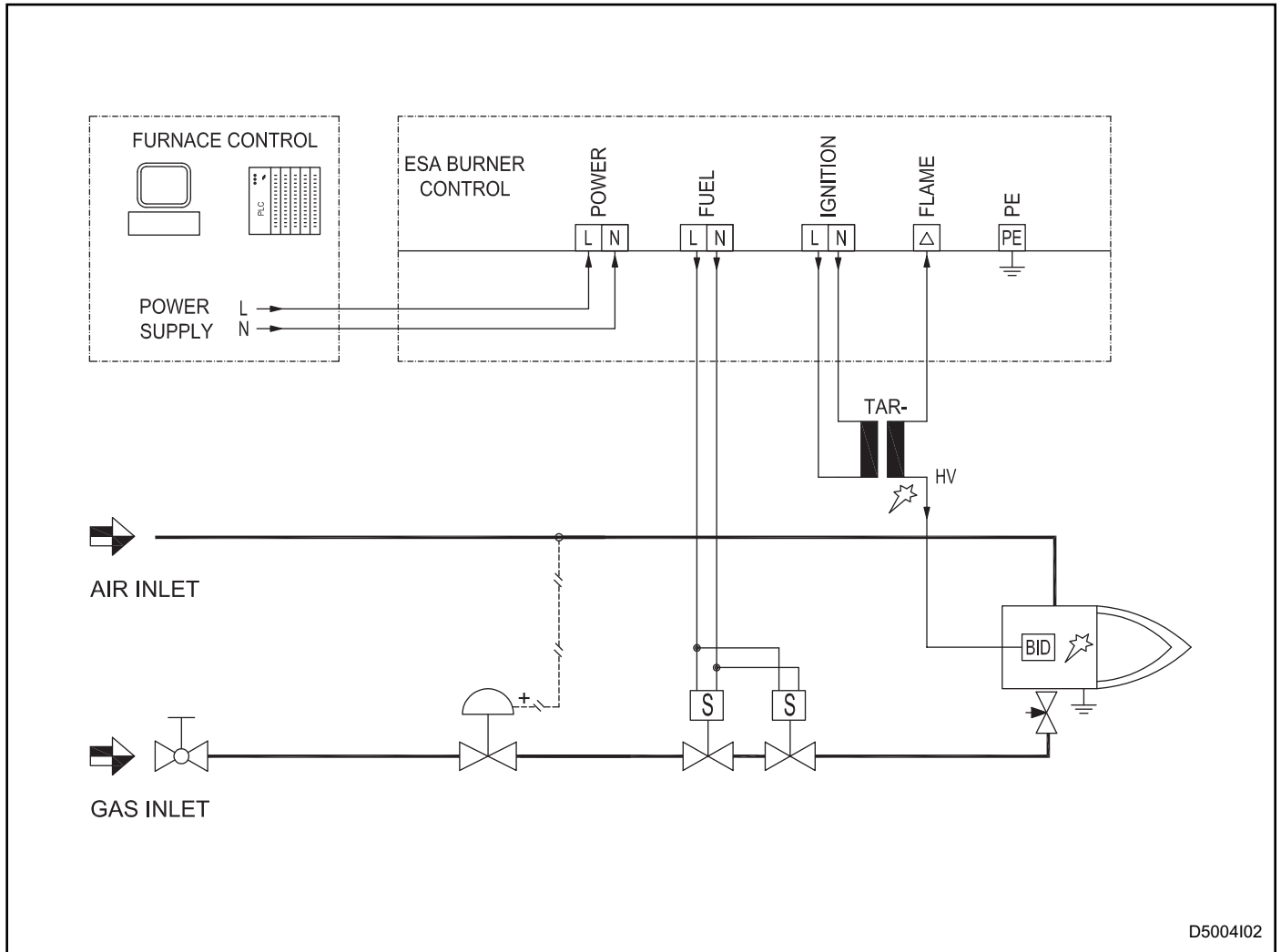

EXAMPLES OF APPLICATION 3 - TAR

The TAR ignition transformer is used to trigger off a burner that requires a constant spark to be able to function. With the use of the transformer for continuous ignition the electric wiring has the HV output connected to the relative

ve burner ignition electrode (BI), while the other transformer secondary head must be connected to earth (see paragraph "Electric wiring"). In this application TAR-13 must be used.

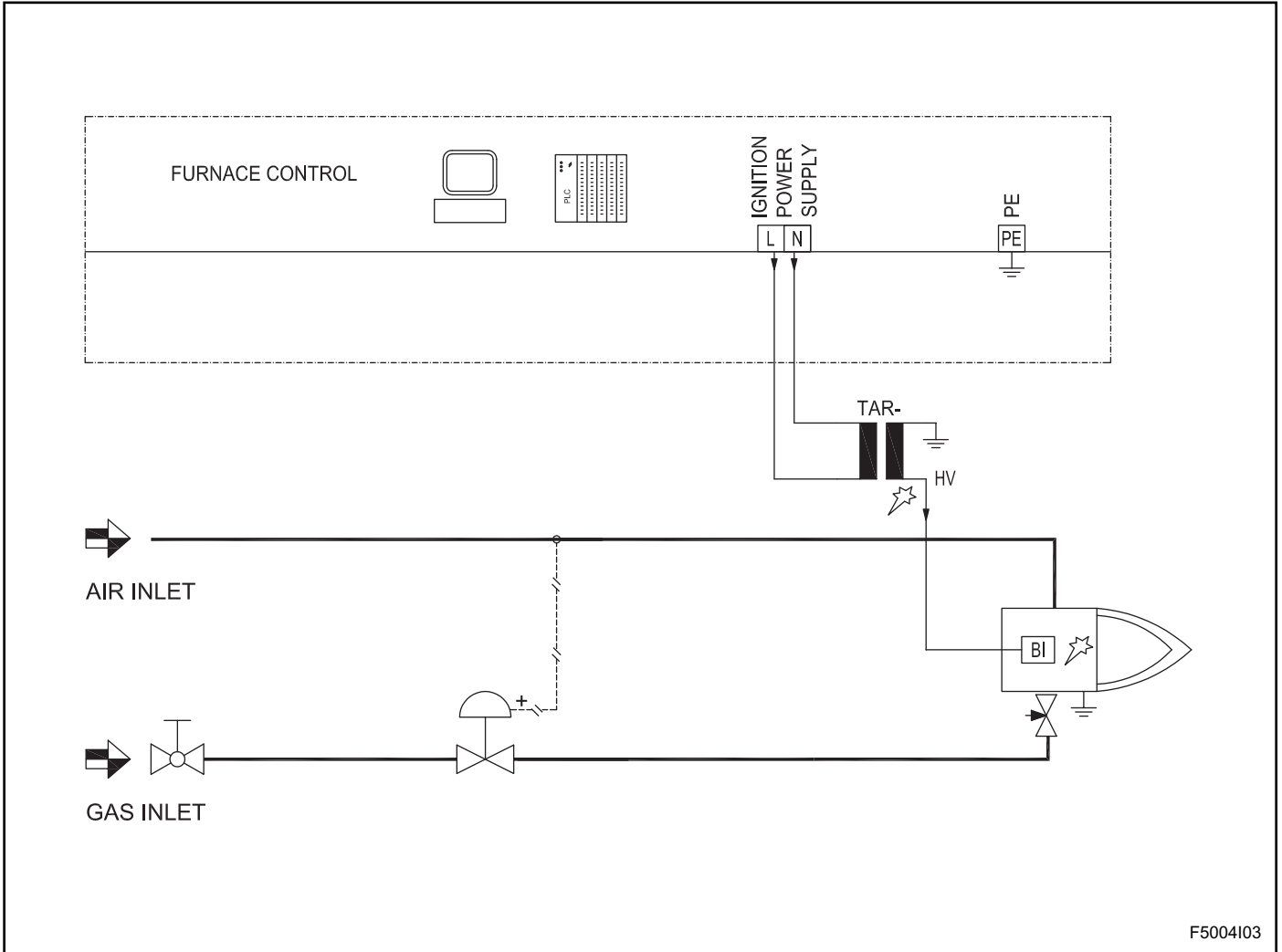

F5004I03

WARNINGS

For correct use of the transformer, the following instructions must be respected:

- When choosing the TAR transformer model you must take into the account the use of the electrode (if it is only for ignition or also for flame detection) as well as the operation duty cycle needed from the application. Before installing the device check that its characteristics conform as defined.
- This device must be electrically connected in a permanent or fixed way. Check the correct connection after installation making sure the voltage and supply frequency are correct.
- The TAR transformer must be placed so that the length of the high voltage cable does not exceed the allowed measurement. If the HV transformer is inside the burner control device, that due to plant reasons, cannot be brought close to the actual burner, it is necessary to extract the transformer and place it near the burner. If necessary in another container (e.g. ESA TRAF0 box).
- If there is disturbance to other equipment (EMC inter-

ference) during the burner ignition phase, use the supressor connector to connect the HV cable to the ignition electrode. Also verify, that the cable is installed correctly (see "Installation" chapter) and that the HV cable is properly connected to the transformer and the electrode connector.

- Make sure that the TAR ignition transformer is powered only when the HV output is connected to the burner ignition electrode. Connection failure causes irreparable damage and a dangerous condition for the application and for the operator.
- To ensure the operator's safety, it is strictly forbidden to touch the HV connection and burner electrode during operation of the ignition transformer, due to the high voltage present. Before performing any operation, make sure to disconnect the power to the TAR transformer.
- For Unirod detection systems use only specific ignition transformers, which allow the operation for ignition and detection with a single electrode. Ensure the correct connection of the protective earth to the device before switching on to avoid irreparable damage.

INSTALLATION

For correct installation, follow the steps below:

- 1** - The installation should be performed by qualified personnel in compliance with the regulations in force at the time and place of installation.
- 2** - Avoid placing the equipment near intense magnetic or electric fields, and in conditions of direct exposure to heat or products resulting from combustion, such as corrosive liquids, solvents or gases.
- 3** - Do not limit in any way the area around the device, but ensure space and adequate ventilation to prevent overheating of the device.
- 4** - The transformer must be positioned so that the HV output is far from metal masses or control cards, to prevent electrical arcs being generated at the output of the transformer instead of on the electrode of the burner, causing irreparable damage.

5 - The connection of the ignition transformer to the relative burner electrode must be done with an unshielded HV cable (high voltage) which is specifically for high voltage, series VS or GVR. Use the connector with supressor for the connection of the the ignition electrode. The cable length must not exceed the indicated measurements otheriwse the ignition transformer must be positioned in the burner vicinity. The HV cable must be put far from power cables and not in metallic conduits: ideally, it should be left in open air.

6 - The laying out of the HV ignition cables must be done separately from the flame detection cables and from other conductors. It is forbidden to position them close to cables coming from other ignition transformers. Do not place them in metallic conduits either.

7 - The type of HV cables between conductors must ensure the minimum insulation required. It is not permissible to use shielded cables for the HV connection between transformer output and ignition electrode.

INSTALLATION

8 - The ignition electrodes and any connectors must be isolated and out of reach by using protective gear, to allow access only to authorized personnel; if it is considered necessary, warnings must be placed close to the probes.

9 - The ignition electrode of the burner must be positioned so that the distance between the terminal electrode and the metal mass, at the point where the burner is ignited, is less than the maximum allowed.

10 - Always make sure that the protective earth is connected to its terminals, to any metallic frames connected and to the burner with appropriate conductors. The non-connection of the protective earth to the device, determines irreparable damage as well as dangerous conditions for the application and for the operator.

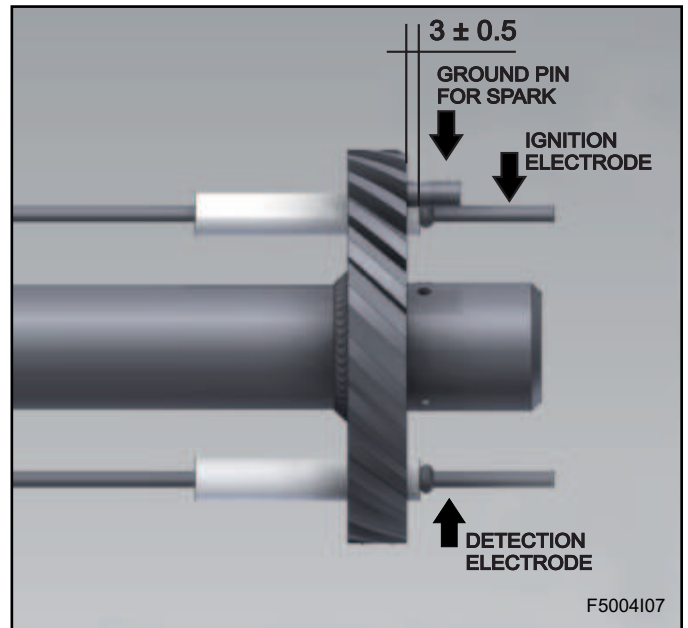

HV CABLE CONNECTION

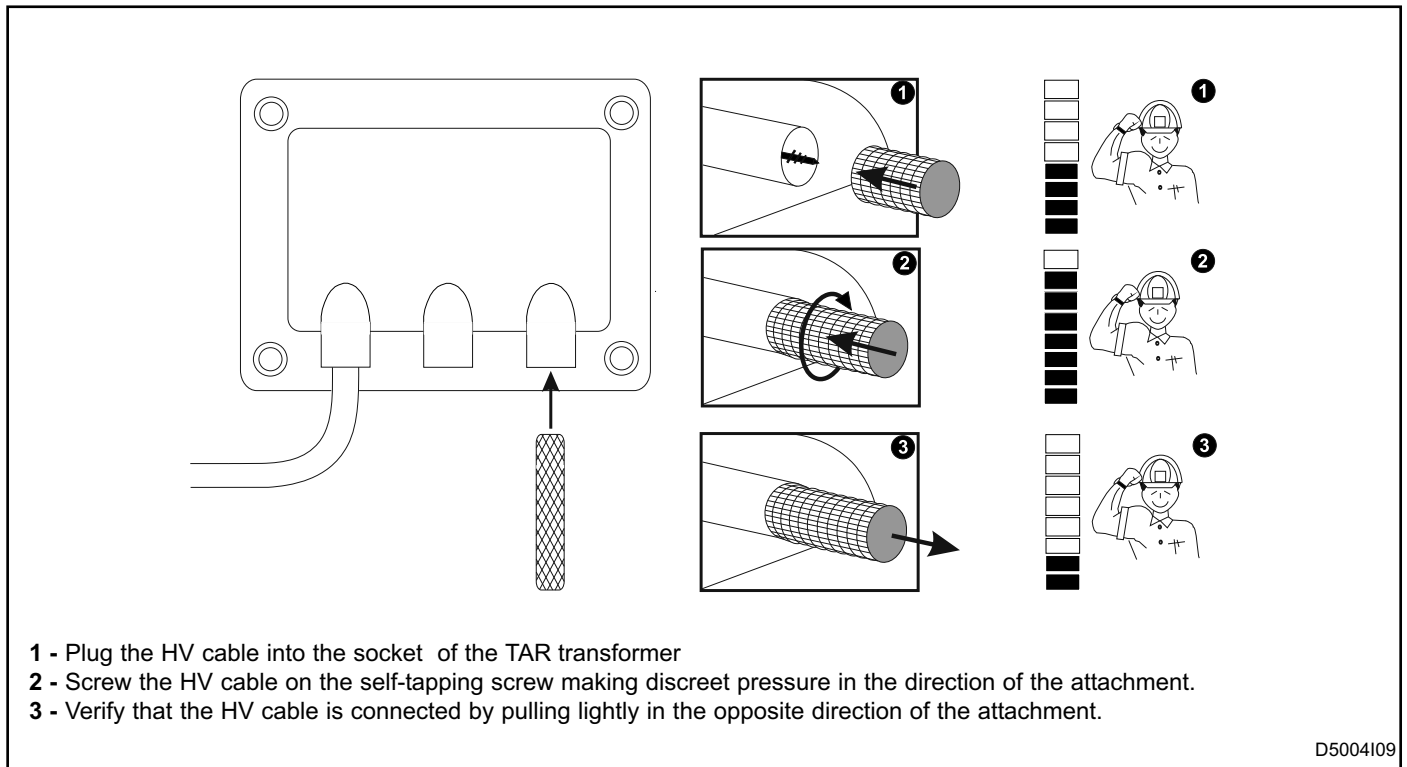

- 1 - Plug the HV cable into the socket of the TAR transformer
- 2 - Screw the HV cable on the self-tapping screw making discreet pressure in the direction of the attachment.
- 3 - Verify that the HV cable is connected by pulling lightly in the opposite direction of the attachment.

INSTALLATION

INTINERY CHOICE HV CABLE

OPTIMAL CONDITIONS

TAR HV silicon cable / burner in open air.

D5004I04

NON RECOMMENDED CONDITIONS

TAR HV silicon cable / burner in plastic pipes.

□ material: PP - PE - PVC

D5004I05

HIGHLY NON RECOMMENDED CONDITIONS

TAR HV silicon cable / burner in metal pipes

■ material: Cro Ni - Al - Cu - Fe

D5004I06

HIGHLY NON RECOMMENDED CONDITIONS

TAR HV silicon cables / heavy burners in the same metal or plastic pipe

■ material: Cro Ni - Al - Cu - Fe

□ material: PP - PE - PVC

D5004I07

HV SILICON CABLE LENGTH

HV Cable (High Voltage) see technical data sheet E5001

NB: Observe the maximum permissible cable length according to the transformer model chosen, by referring to "SPECIFICATIONS" on p. 3/4

D5004I08

START-UP

The operations indicated in the following chapter must be performed by expert technicians. Failure to follow directions may cause dangerous conditions.

1 - Check that the transformer is properly installed. The HV output should be sufficiently far from metallic masses such as containers (boxes) or control cards.

2 - Check that the HV cable is securely connected to the output of the transformer and the electrode of the burner, with the conductor insulation fully inserted in the connection points.

3 - Check that the HV connectors are securely connected to the burner electrode and that there are no unprotected electrode metallic parts.

4 - Check that the distance between the electrode terminal and the metal mass, at the point of the burner ignition is less than the maximum allowed.

5 - Be sure to respect the duty cycle operation of the transformer TAR, checking the settings of the control device.

6 - After the previous verifications, use the control device to activate the ignition transformer. Visually check that during the operating time of the transformer, the electric arc discharge is formed in the right place in the burner.

GENERAL MAINTENANCE PLAN

Check	Type	Advised time	Operation
Integrity of connecting cables	O	every six months	Check the integrity of the outer insulation and the absence of abrasions or overheating signal of the conductor
Discharge intensity	O/E	every six months	Visually check the intensity of the electric discharge on the electrode.
Clamping of conductors	O/E	annual	Reduce to every six months for applications with vibrations.
Ignition electrode state	E	annual	Check the distance of the terminal point and the physical condition of the ignition electrode..
Replacement of the TAR ignition transformer	E	/	Replacement is necessary if the device is no longer functioning.

NOTES:

Key: O = ordinary / E = extraordinary.

ORDINARY MAINTENANCE

For proper maintenance of the TAR ignition transformers strictly follow the instructions. Before carrying out maneuvers with the system on, ensure that the process and operator safety is not compromised. If possible perform all inspections with system off.

INTEGRITY CHECKS

■ The integrity of electrical cables can be checked visually. If you need to check the conductors, seen as they are not completely visible, disconnect the power to the device before attempting any operation.

DISCHARGE INTENSITY CHECK

■ The check is carried out visually during the operation

time of the transformer, checking that the electric arc discharge is formed in the right place in the burner and that it has not reduced the intensity

CLAMPING OF CONDUCTORS

■ The verification of the clamping of the conductors is true both for the power supply of the HV transformer as well as for the HV conductor connected to the output of the transformer and to the burner ignition electrode. Disconnect the power supply to the TAR transformer before performing this test.

EXTRAORDINARY MAINTENANCE

For proper maintenance of the TAR ignition transformers, strictly follow the instructions to be carried out with the system turned off.

IGNITION ELECTRODE STATUS CHECK

1 - Turn off electrical power to the ignition transformer, then remove the HV connector from the ignition electrode.

2 - Following the instructions of the burner, remove the affected part until you can see the physical condition of the ignition electrode at the actual point where the flame is ignited. Also make sure that the distance between the terminal point and the metal mass of the burner, is less than the maximum allowed

3 - If the ignition electrode is damaged it must be replaced. Then replace the part of the burner that has been removed following the specific instructions.

4 - Check the operation following the replacement by repeating all the steps in "START-UP".

TRANSFORMER REPLACEMENT

1 - Make sure that the ignition transformer TAR is the cause of the failure or improper operation and that you have a spare transformer that is the same as the one being replaced, checking the data on the identification label.

2 - Turn off the power supply and then disconnect the electrical connection of the transformer. In this phase it is important to have the conductors numbered to avoid problems during reconnection.

3 - Remove the fixing screws and remove the transformer from the support structure.

4 - Fasten the new ignition transformer on making sure that the HV output is far enough from metal masses such as containers (boxes) or control cards.

5 - Restore the electrical connections, referring to the wiring diagram

6 - Check the operation following the replacement by repeating all the steps in "START-UP".

ELECTRICAL CONNECTION

The TAR transformers can be used with various control devices. To define the electrical connections between them and the TAR ignition transformer series, refer to

the technical documentation of the control device and the functions of each conductor of the transformer.

Model	Use	Wire colours				
		Primary phase	Neutral phase	HV Output (High Voltage) towards electrode	Detection signal	Earth
TAR-10	ignition and detection	black	blue	selfthreading screws	brown (*)	yellow green
	only ignition	black	blue		-	brown yellow green
TAR-11	only ignition	brown	blue		-	yellow green
TAR-12	ignition and detection	black	blue		brown (*)	yellow green
	only ignition	black	blue		-	brown yellow green
TAR-13	only ignition	brown	blue		-	yellow green

(*) only with Esa Pyronics instruments

DISCONTINUED MODELS

Model	Use	Wire colours				
		Primary phase	Neutral phase	HV Output (High Voltage) towards electrode	Detection signal	Earth
TAR-2	only ignition	brown	blue	selfthreading screws	-	yellow green
TAR-4	ignition and detection	black	blue		brown (*)	yellow green
	only ignition	black	blue		-	brown yellow green
TAR-5	only ignition	brown	blue		-	yellow green
TAR-6	ignition and detection	brown	blue		yellow green	(*)
	only ignition	brown	blue		-	yellow green
TAR-7	ignition and detection	black	blue		brown (*)	yellow green
	only ignition	black	blue		-	brown yellow green
TAR-8	only ignition	brown	blue		-	yellow green

(*) only with Esa Pyronics instruments

OVERALL DIMENSIONS TRANSFORMER TAR-10

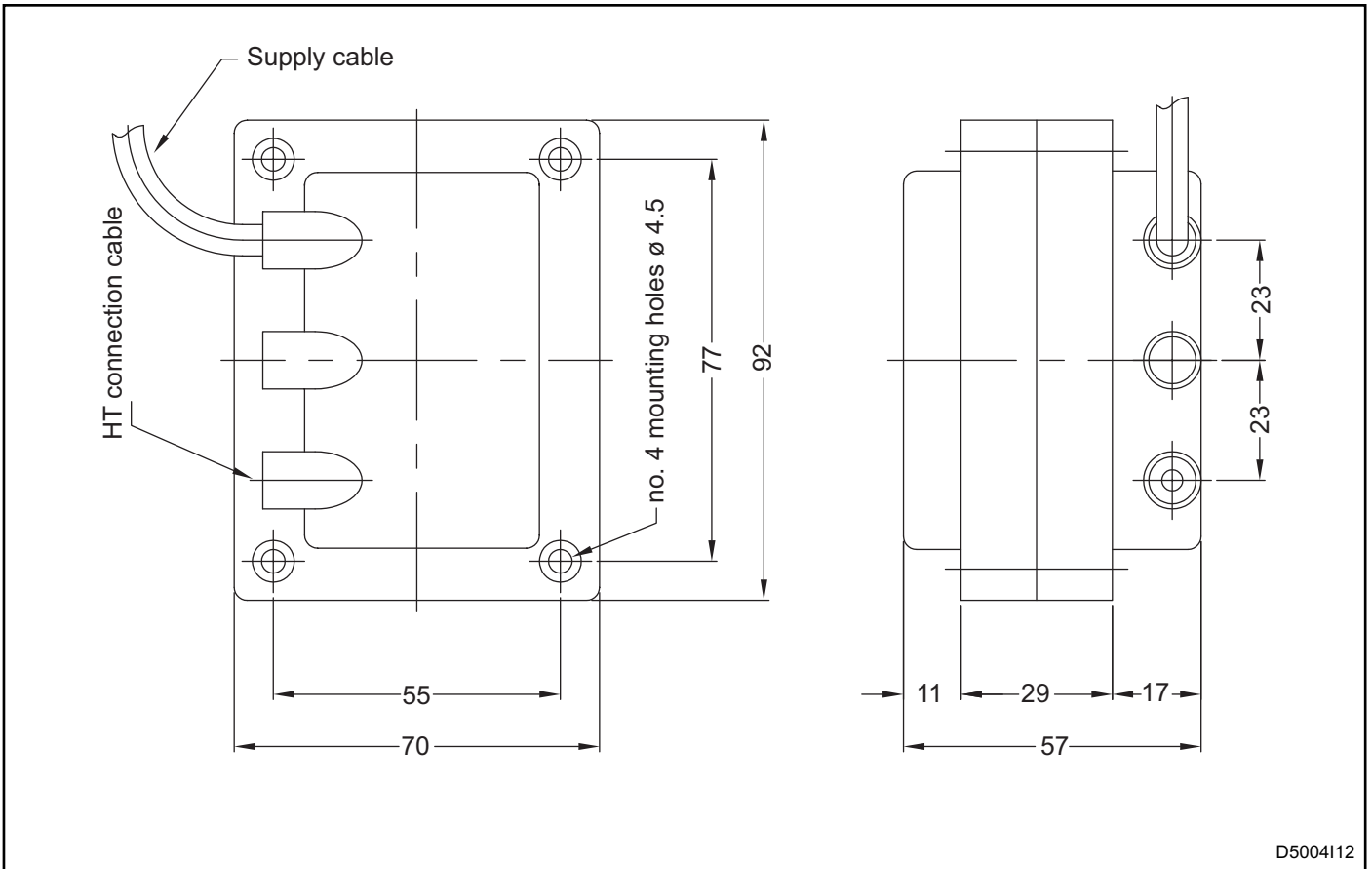

OVERALL DIMENSIONS TRANSFORMER TAR-11

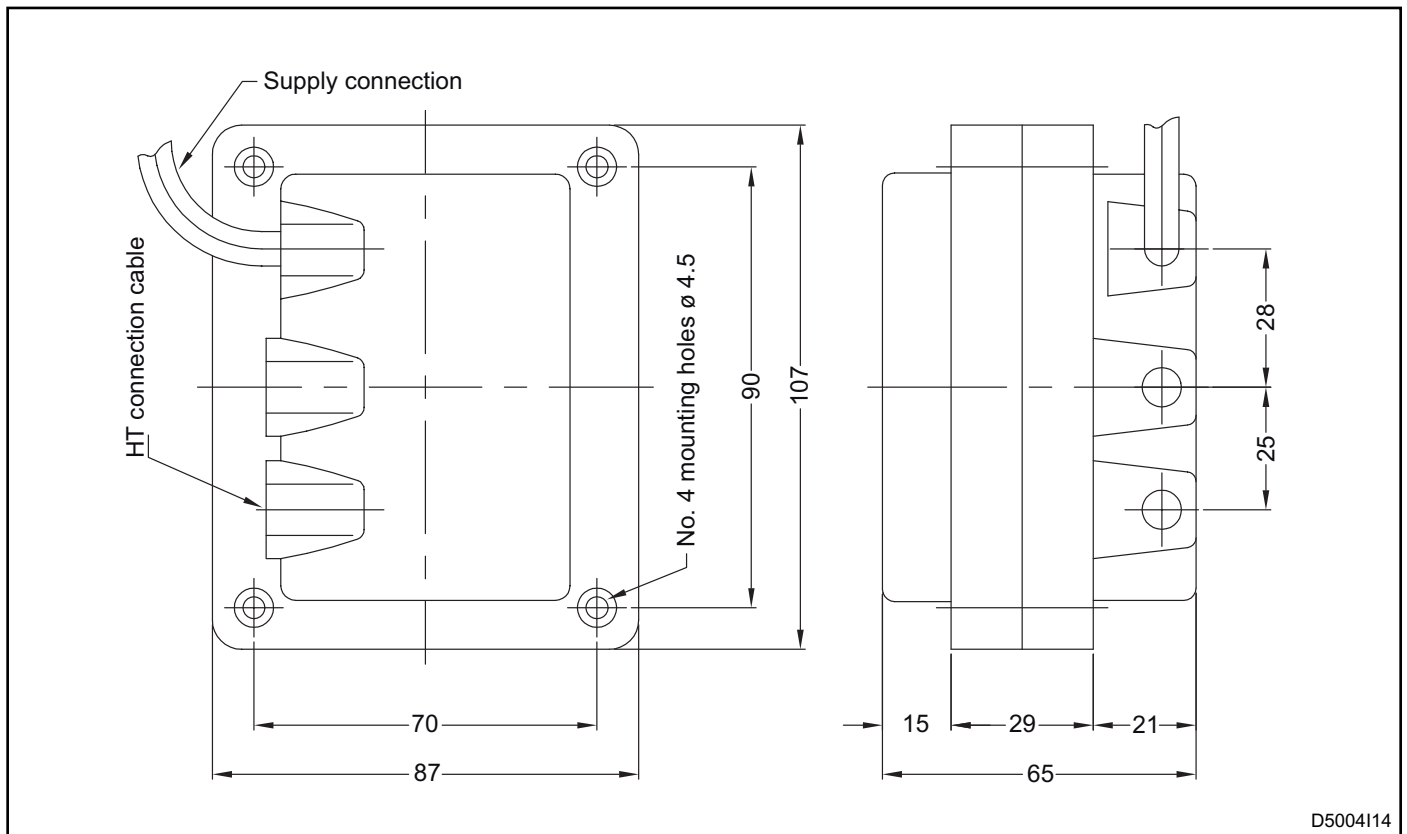

OVERALL DIMENSIONS TRANSFORMER TAR-12

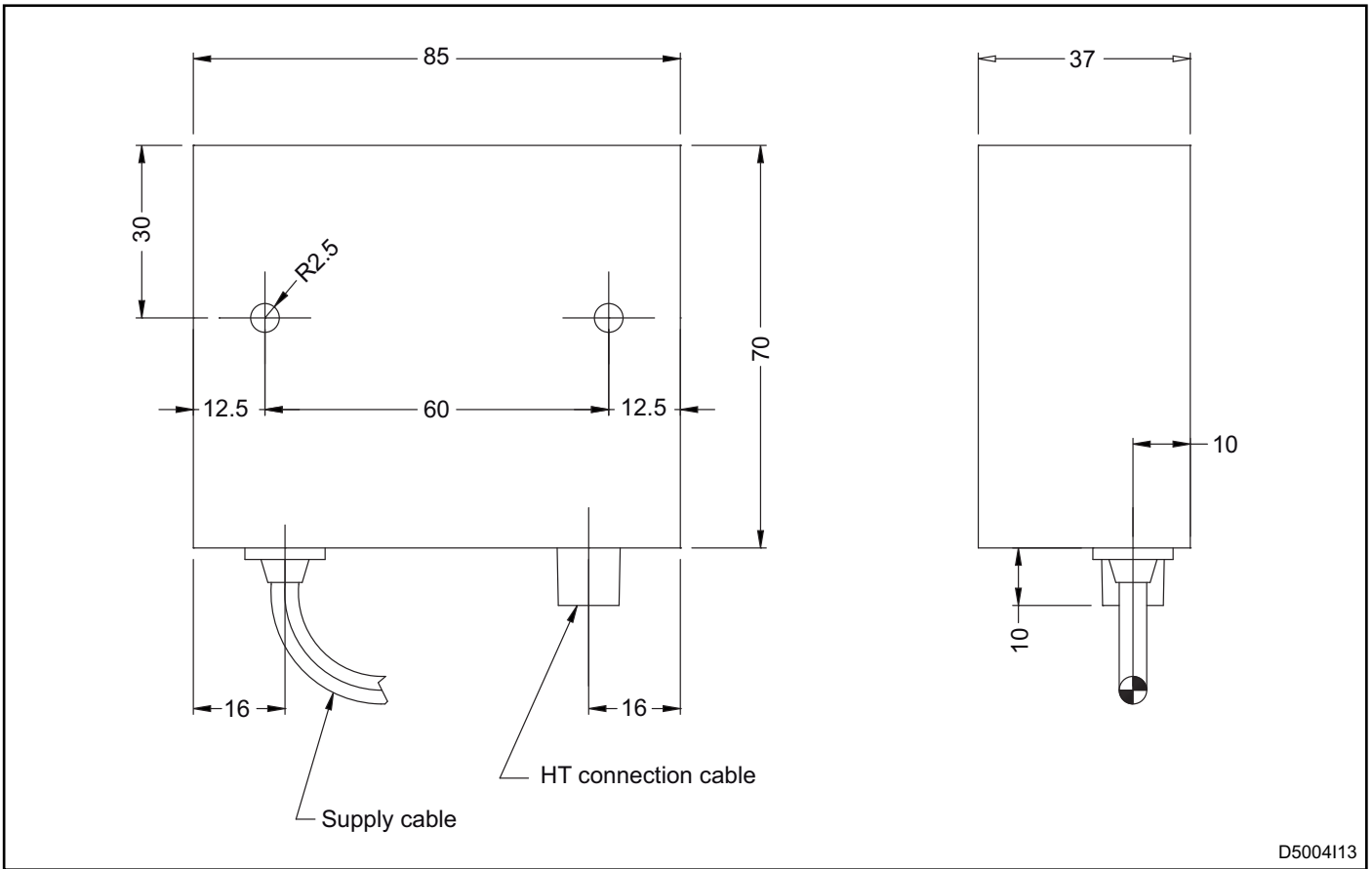

OVERALL DIMENSIONS TRANSFORMER TAR-13

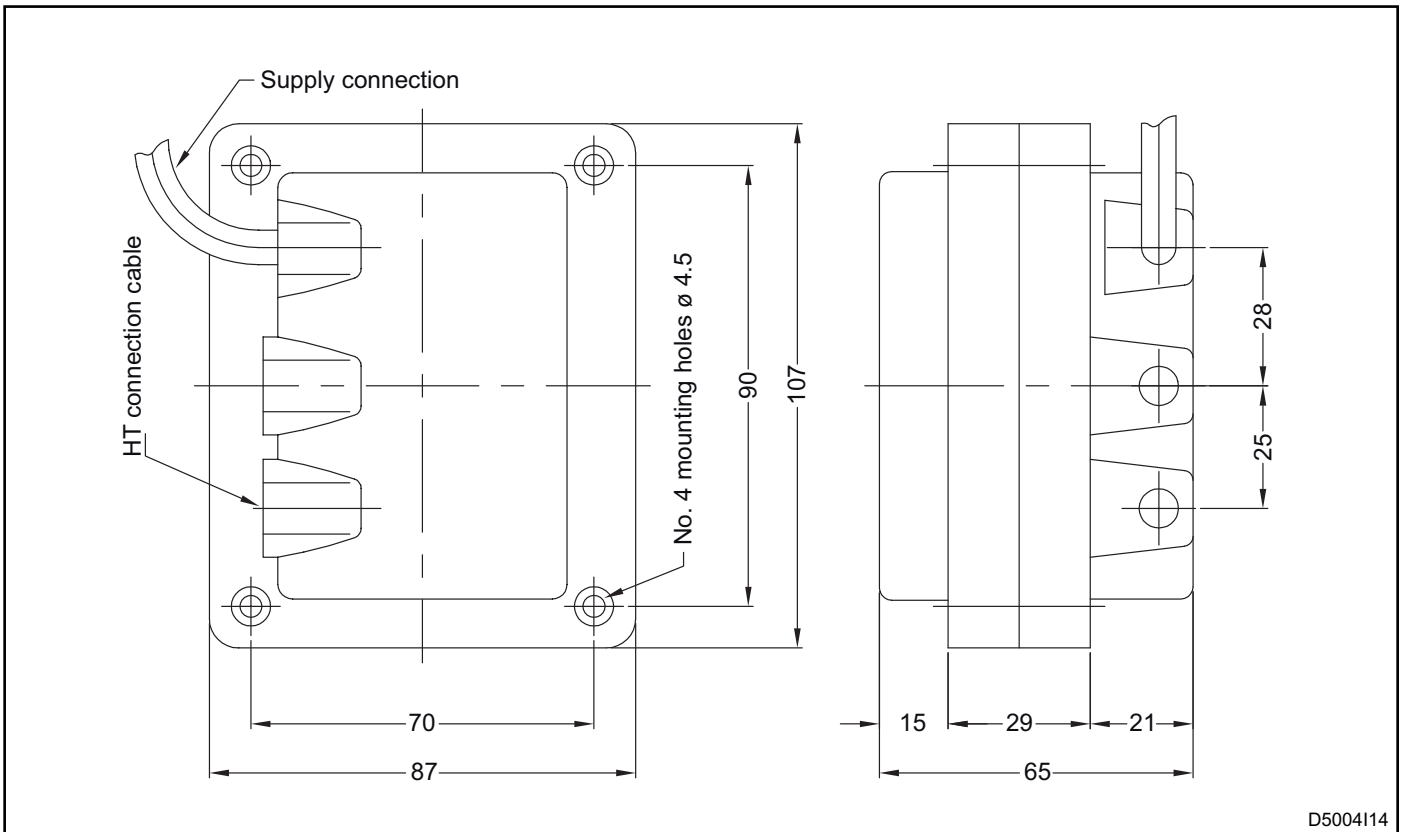

DISCONTINUED TRANSFORMERS

TAR-2 CHARACTERISTICS

- Primary voltage: 110 / 220 V
- Frequency: 50 Hz
- Secondary voltage: 1 x 9KV
- Primary current: 2,2 / 1,1 A
- Secondary current: 20 mA
- Power absorbed: 240 VA
- Intermittency in 3 min.: 33%
- Mass: 2 kg
- Power cable length: 55 cm
- HV attachment: self threading
- HV cable maximum length.: 1 m
- Transformer use: only ignition

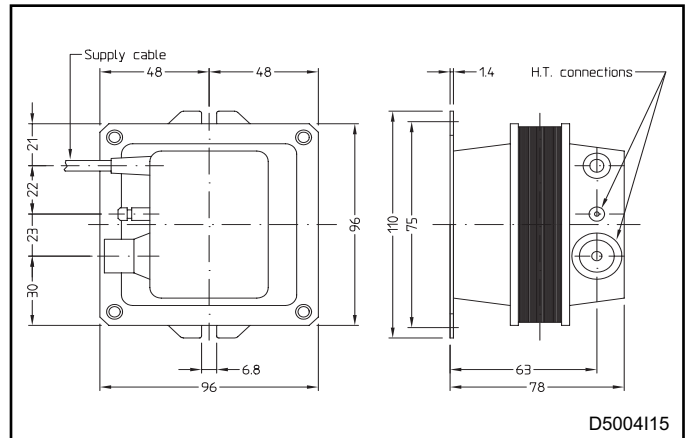

TAR-4 CHARACTERISTICS

- Primary voltage: 115 / 230 V
- Frequency: 50 Hz
- Secondary voltage: 1 x 5KV
- Primary current: 0,9 / 0,45 A
- Secondary current: 13 mA
- Power absorbed: 105 VA
- Intermittency in 3 min.: 15%
- Mass: 1 kg
- Power cable length: 25 cm
- HV attachment: self threading
- HV maximum cable length: 1 m
- Transformer use: ignition and detection

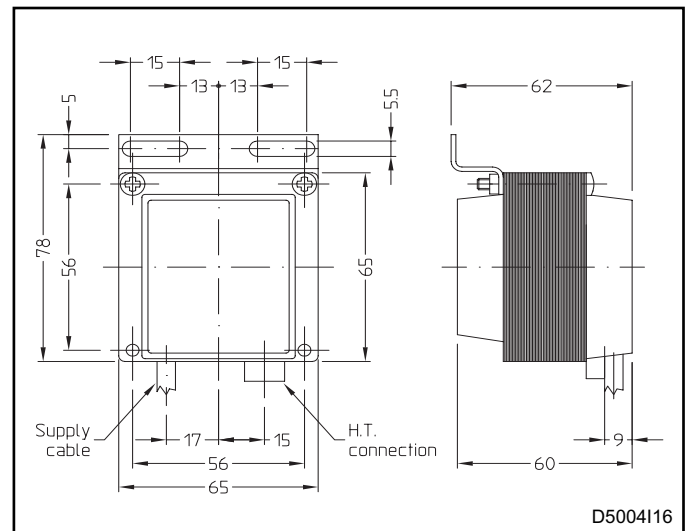

TAR-5 CHARACTERISTICS

- Primary voltage: 110 / 220 V
- Frequency: 50 Hz
- Secondary voltage: 1 x 8KV
- Primary current: 1,3 / 0,65 A
- Secondary current: 16 mA
- Power absorbed: 145 VA
- Intermittency: 100 %
- Mass: 2 kg
- Power cable length: 55 cm
- HV attachment: self threading
- HV maximum cable length: 1 m
- Transformer use: only ignition

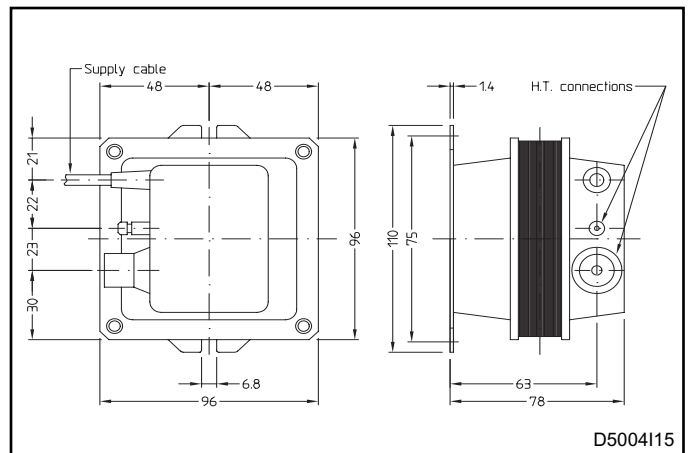

DISCONTINUED TRANSFORMERS

TAR-6 ELECTRONIC CHARACTERISTICS

- Primary voltage: 110/220 V
- Frequency: 50/60 Hz
- Secondary voltage: 1 x 15KV
- Primary current: 0,4 / 0,2 A
- Secondary current: 25 mA
- Power absorbed: 45VA
- Intermittency in 3 min.: 50%
- Mass: 370g
- Power cable length: 56 cm
- HV attachment: self threading
- HV maximum cable length: 1 m
- WAND maximum length: 70mm
- Transformer use: ignition and detection

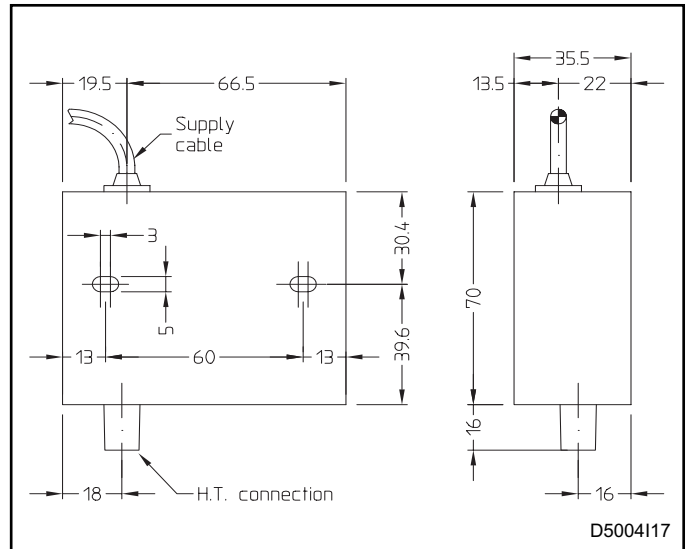

D5004I17

TAR-7 CHARACTERISTICS

- Primary voltage: 115 / 230 V
- Frequency: 50/60 Hz
- Secondary voltage: 1 x 8KV
- Primary current: 1 A
- Secondary current: 20 mA
- Power absorbed: 220 VA
- Intermittency in 3 min.: 25%
- Mass: 1,9 kg
- Power cable length: 38 cm
- HV attachment: self threading
- HV maximum cable length: 1 m
- Transformer use: ignition and detection

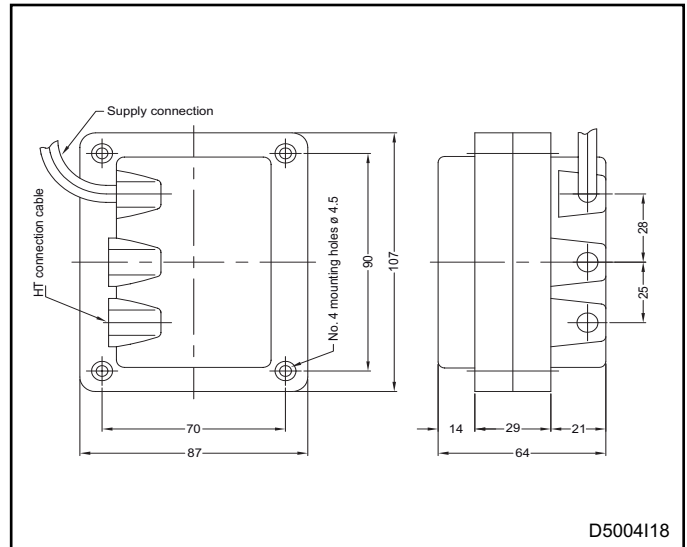

D5004I18

TAR-8 CHARACTERISTICS

- Primary voltage: 115 / 230 V
- Frequency: 50/60 Hz
- Secondary voltage: 1 x 8KV
- Primary current: 1 A
- Secondary current: 20 mA
- Power absorbed: 220 VA
- Intermittency in 3 min.: 25%
- Mass: 1,9 kg
- Power cable length: 38 cm
- HV attachment: self threading
- HV maximum cable length: 1 m
- Transformer use: only ignition

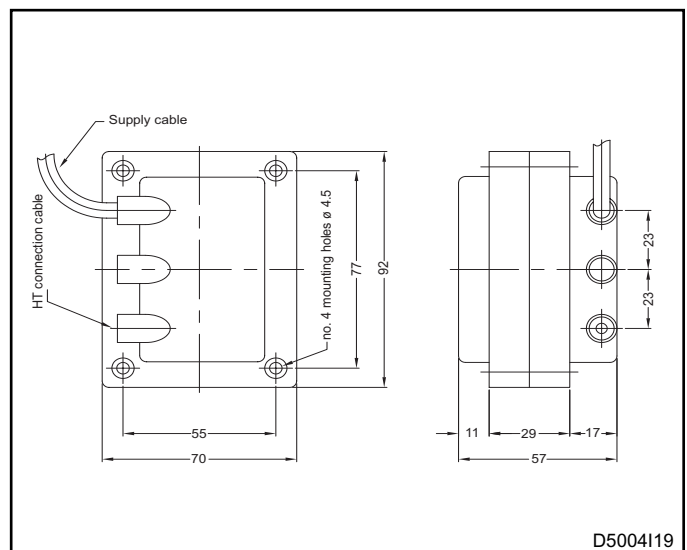

D5004I19

ORDERING CODE



Model		01
TAR-10 transformer	10	
TAR-11 transformer	11	
TAR-12 transformer	12	
TAR-13 transformer	13	

Supply voltage		02
230Vac		230
115Vac		115